

PUMP STATION SPECIFICATIONS:

NAME: TYPICAL SSSL-EVOLUTION

STATION MODEL: SSSL

STATION TOTAL PERFORMANCE : GPM @ PSI

PUMP HORSEPOWER:

PUMP NO.1 HP

PUMP NO.2 HP

CHECK VALVE SIZES:

PUMP NO.1 -

PUMP NO.2 -

ISOLATION VALVE SIZES:

PUMP NO.1 -

PUMP NO.2 -

DISCHARGE ISOLATION VALVE SIZE: (AS REQUIRED)

DISCHARGE MANIFOLD SIZE: (AS REQUIRED)

MAIN DISCONNECT : AMP

POWER REQUIREMENTS: - VOLTS , -HERTZ , -PHASE , - FLA

EXHAUST FAN REQUIREMENTS: 240 CFM

STATION COMPONENTS:

A HP PUMP AND MOTOR

B HP PUMP AND MOTOR

C PUMP AND MOTOR CHECK VALVE

D POSITIVE PRIME ASSEMBLY

E PRESSURE GAUGE

F PUMP-2 INTAKE FLANGE W/ FILL PORT

G PUMP-1 INTAKE FLANGE W/ FILL PORT

H PUMP STATION HEATER (OPTIONAL)

I PRESSURE TRANSDUCER W/ PRESSURE GAUGE

J FLOW SENSOR

K VFD

L INNER CONTROL CABINET (LOW VOLTAGE)

M STATION DISCONNECT CABINET (HIGH VOLTAGE)

N STATION DISCHARGE ISOLATION VALVE

O PUMP-2 - ELECTRONIC BUTTERFLY VALVE REGULATION (EBV)

P STATION FAN (HOOD MOUNTED)

Q DISCHARGE MANIFOLD DROP PIPE W/ BLOWOUT FITTING (OPTIONAL)

R STATION BASE (PAINTED STEEL)

S STATION ENCLOSURE W/ HOOD (PAINTED STEEL)

T PUMP STATION SUCTION LINE W/ FLOAT AND FOOTVALVE (OPTIONAL)

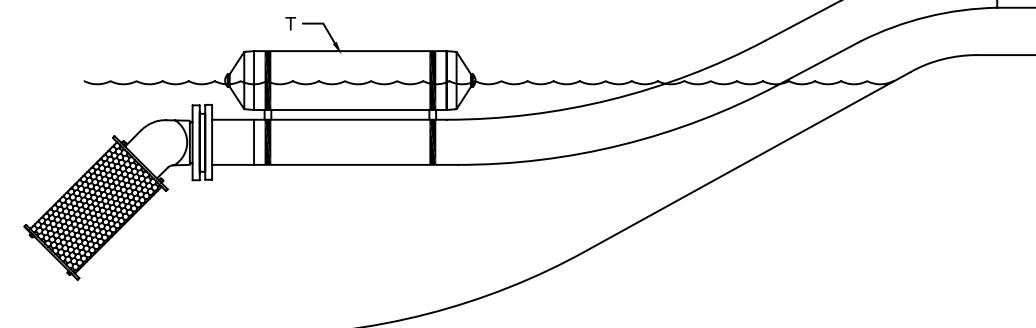
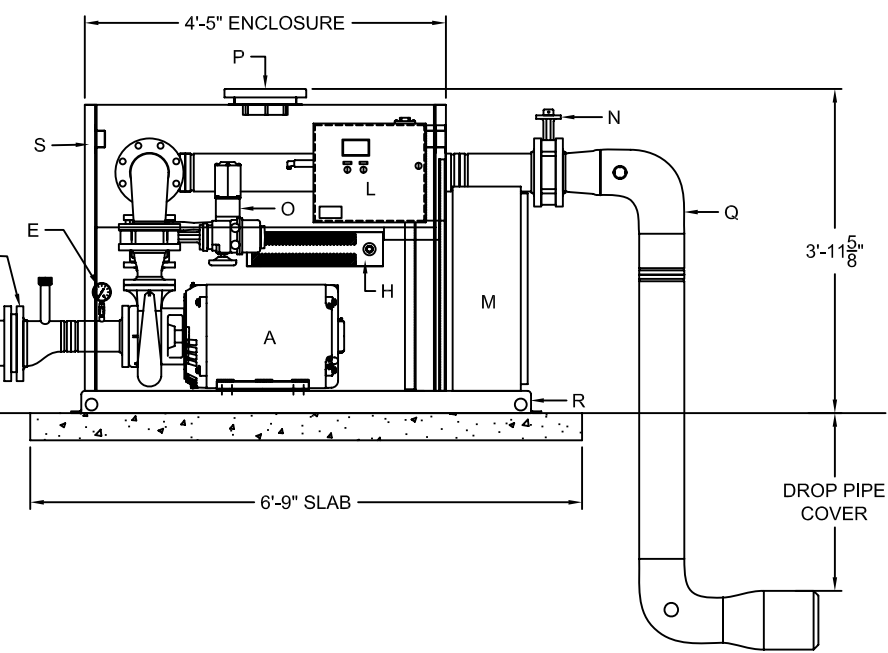
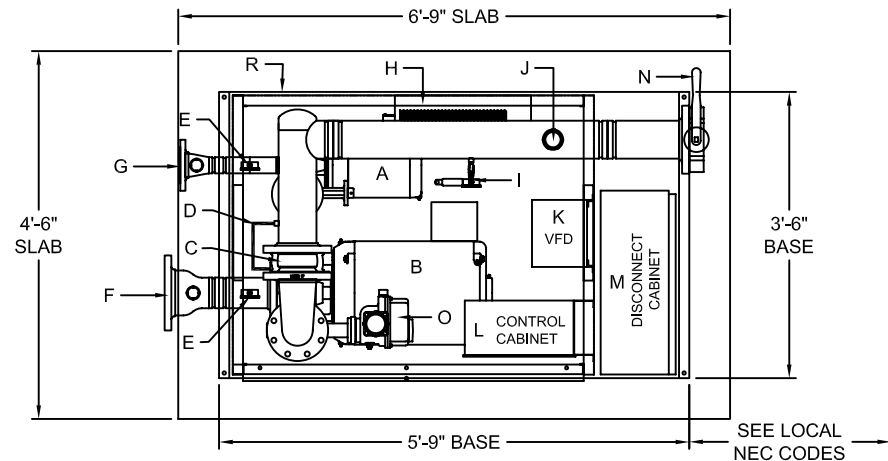

| | | | | |
|---|-----|-------------|-----|-------------|
| CUSTOMER APPROVAL SIGNATURE <input type="checkbox"/> APPROVED AS SUBMITTED <input type="checkbox"/> MAKE INDICATED CHANGES AND RESUBMIT | 7 | | | |
| | 6 | | | |
| | 5 | | | |
| | 4 | | | |
| | 3 | | | |
| | 2 | | | |
| | 1 | ---/---/--- | --- | |
| | NO. | DATE | BY | DESCRIPTION |

| | | | | |
|---|-------------|------|----|----------------|
| 7 | | | | |
| 6 | | | | |
| 5 | | | | |
| 4 | | | | |
| 3 | | | | |
| 2 | | | | |
| 1 | ---/---/--- | --- | | REVISION-NOTE: |
| | NO. | DATE | BY | DESCRIPTION |

SCALE: NONE | DRWN BY: ---
 THIS DRAWING AND DESIGN, IS THE PROPERTY OF WATERTRONICS AND IS NOT TO BE REPRODUCED IN WHOLE OR PART, NOR EMPLOYED FOR ANY PURPOSE OTHER THAN SPECIFICALLY PERMITTED IN WRITING BY WATERTRONICS. THIS DRAWING LOANED AND SUBJECT TO RETURN ON DEMAND

TITLE: TYPICAL SSSL-EVOLUTION SSSL
WATERTRONICS
 ELECTRONICALLY CONTROLLED PUMPING SYSTEMS
 HARTLAND, WISCONSIN
 DATE: DATE SHEET 1 OF 4 SHEETS
 JOB NO.: JOB-NO: DRAWING NO. DRAW-NO: