

**STATION COMPONENTS:**

- A PUMP AND MOTOR
- B CHECK VALVE
- C PRESSURE TRANSDUCER WITH GAUGE
- D BY-PASS VALVE
- E FLOW SENSOR
- F TEMP SENSOR
- G STATION FAN HOOD MOUNTED
- H PUMP INTAKE ISOLATION VALVE
- I PUMP DISCHARGE ISOLATION VALVE
- J STATION DISCHARGE ISOLATION VALVE
- K PAINTED STEEL ENCLOSURE
- L PRESSURE GAUGE LIQUID FILLED

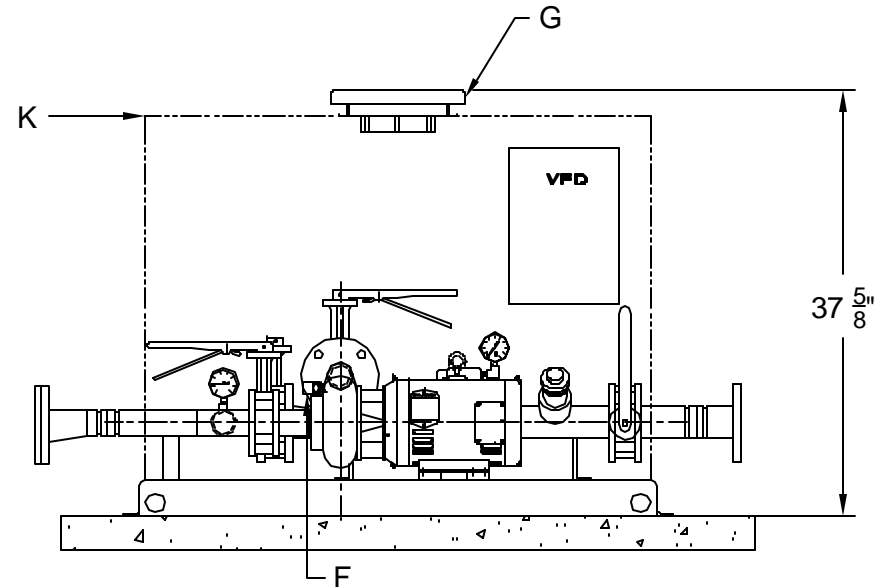
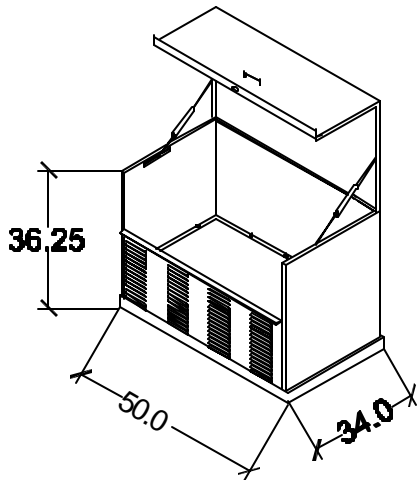
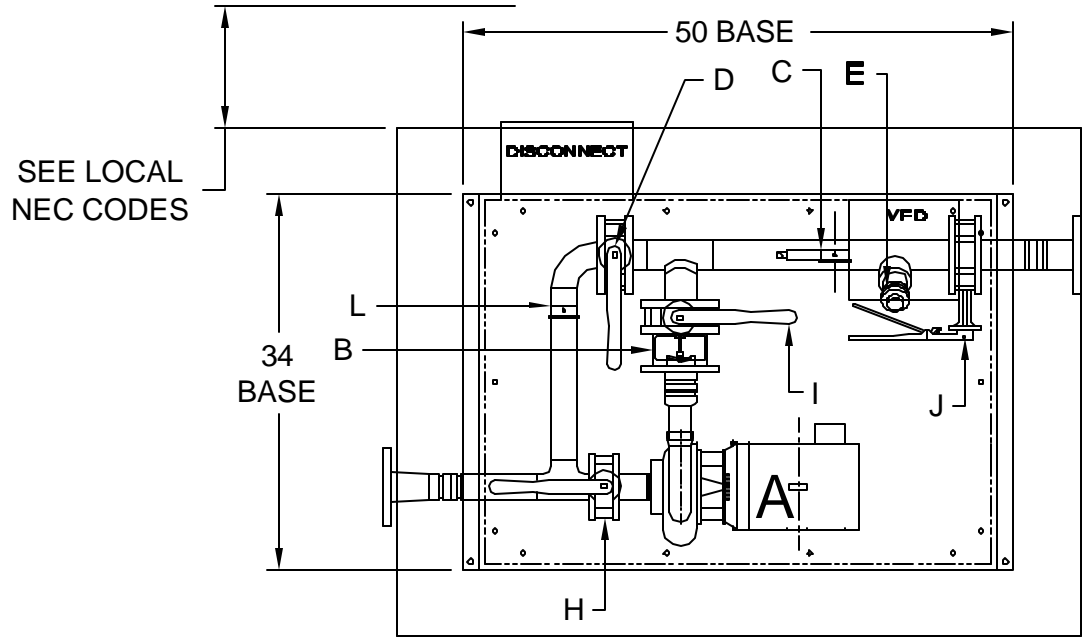

CUSTOMER APPROVAL SIGNATURE

| 7   |       |     |                |
|-----|-------|-----|----------------|
| 6   |       |     |                |
| 5   |       |     |                |
| 4   |       |     |                |
| 3   |       |     |                |
| 2   |       |     |                |
| 1   | --/-- | --- | REVISION-NOTE: |
| NO. | DATE  | BY  | DESCRIPTION    |

SCALE: NONE | DRWN BY: MJW

THIS DRAWING AND DESIGN, IS THE PROPERTY OF WATERTRONICS AND IS NOT TO BE REPRODUCED IN WHOLE OR PART, NOR EMPLOYED FOR ANY PURPOSE OTHER THAN SPECIFICALLY PERMITTED IN WRITING BY WATERTRONICS. THIS DRAWING LOANED AND SUBJECT TO RETURN ON DEMAND

TITLE: STANDARD CLT BOOSTER  
CLTBV-

**WATERTRONICS**  
ELECTRONICALLY CONTROLLED PUMPING SYSTEMS  
HARTLAND, WISCONSIN

DATE: 1/19/04 | SHEET 1 OF 1 SHEETS

JOB NO.: | JOB-NO.: | DRAWING NO. STANDARD

- APPROVED AS SUBMITTED
- MAKE INDICATED CHANGES AND RESUBMIT